

R. S. BROWN.
CHAIN MORTISING MACHINE.

(Application filed Feb. 11, 1898.)

(No Model.)

6 Sheets—Sheet 1.

Fig. 1.

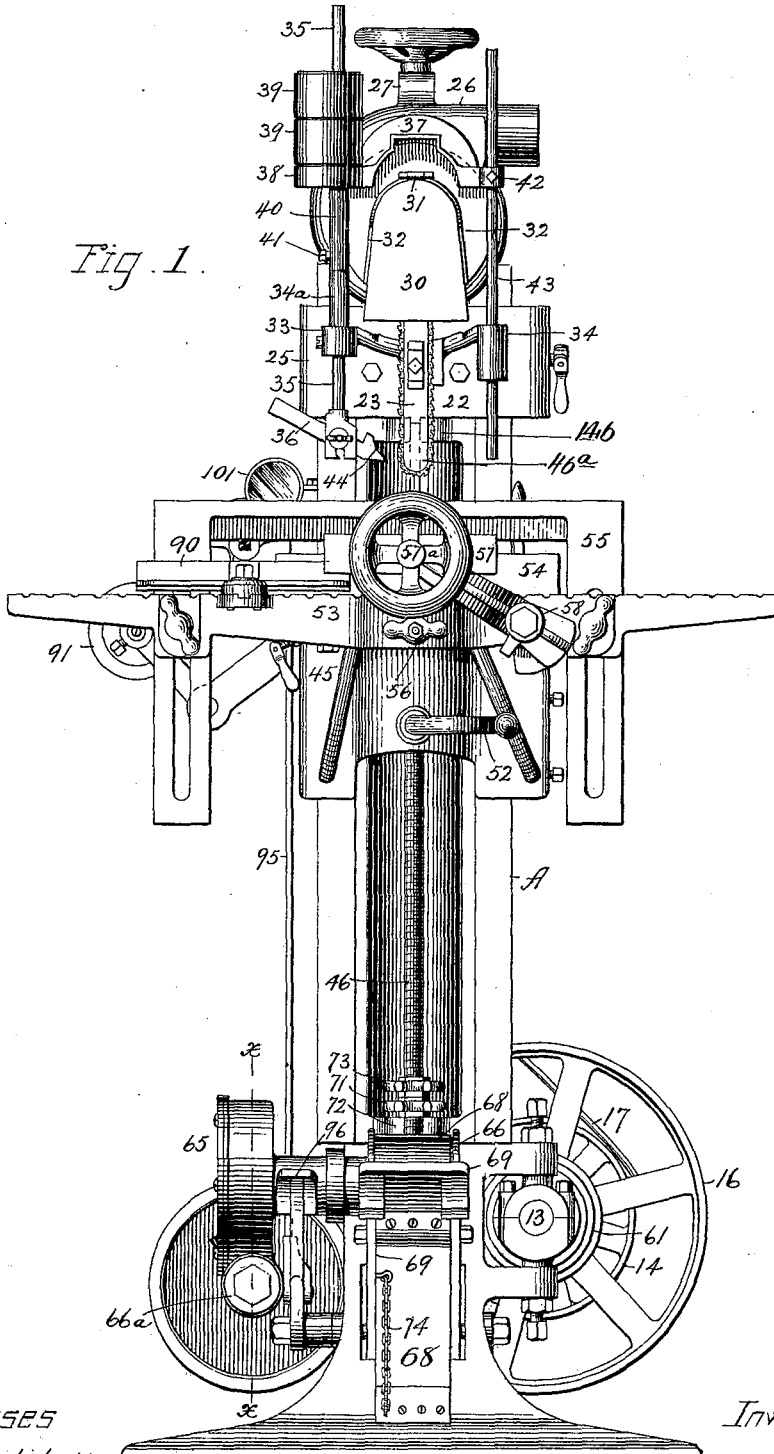

Witnesses
Geo. Shepard
P. J. Egan

Inventor
Robert S. Brown
 By *James Shepard*
 Atty.

R. S. BROWN.
CHAIN MORTISING MACHINE.

(Application filed Feb. 11, 1898.)

(No Model.)

6 Sheets—Sheet 2.

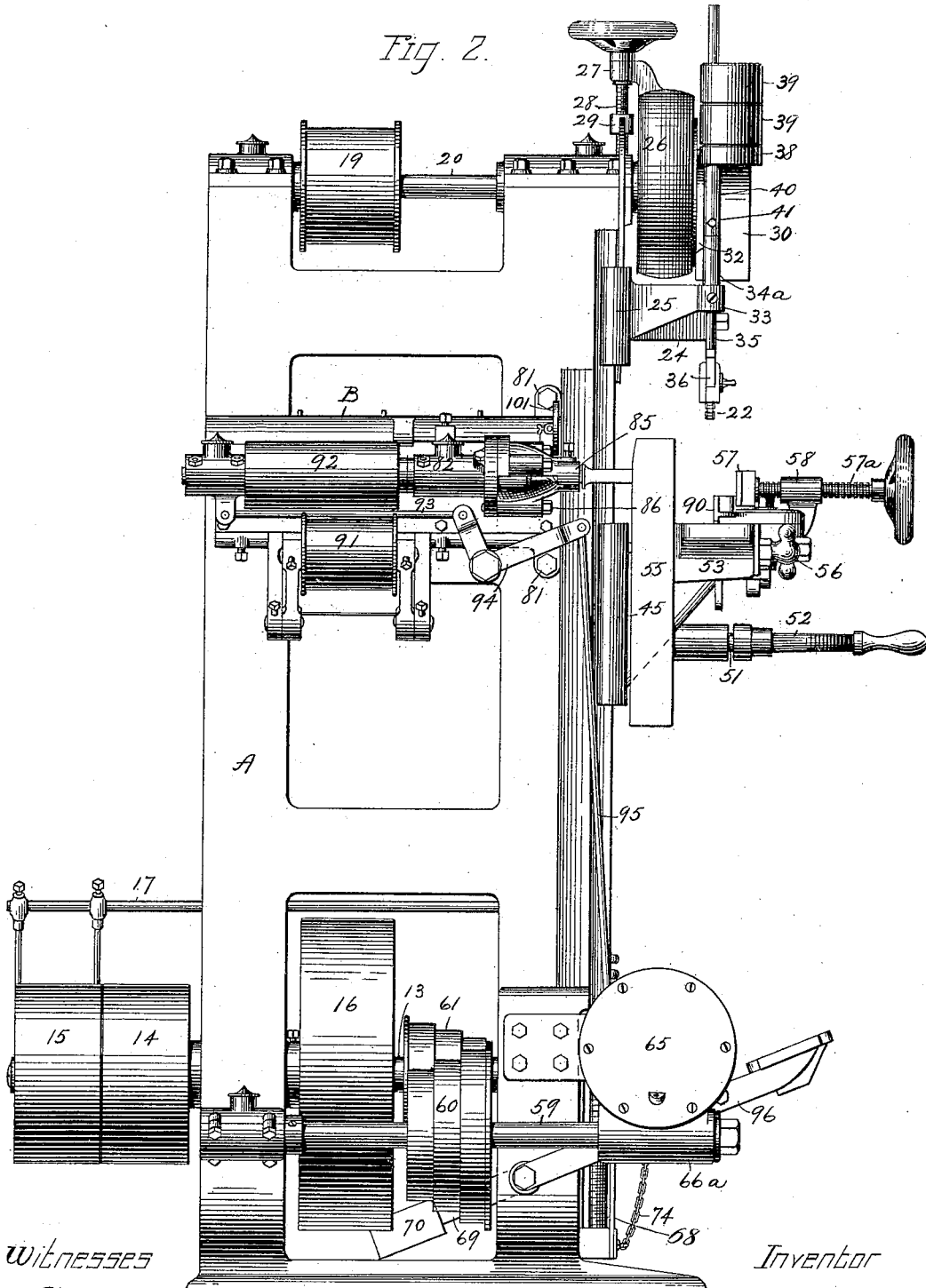

Witnesses

By P. J. Egan

Inventor

Robert S. Brown
By James Shepard
Att'y.

R. S. BROWN.
CHAIN MORTISING MACHINE.

(Application filed Feb. 11, 1898.)

(No Model.)

6 Sheets—Sheet 3.

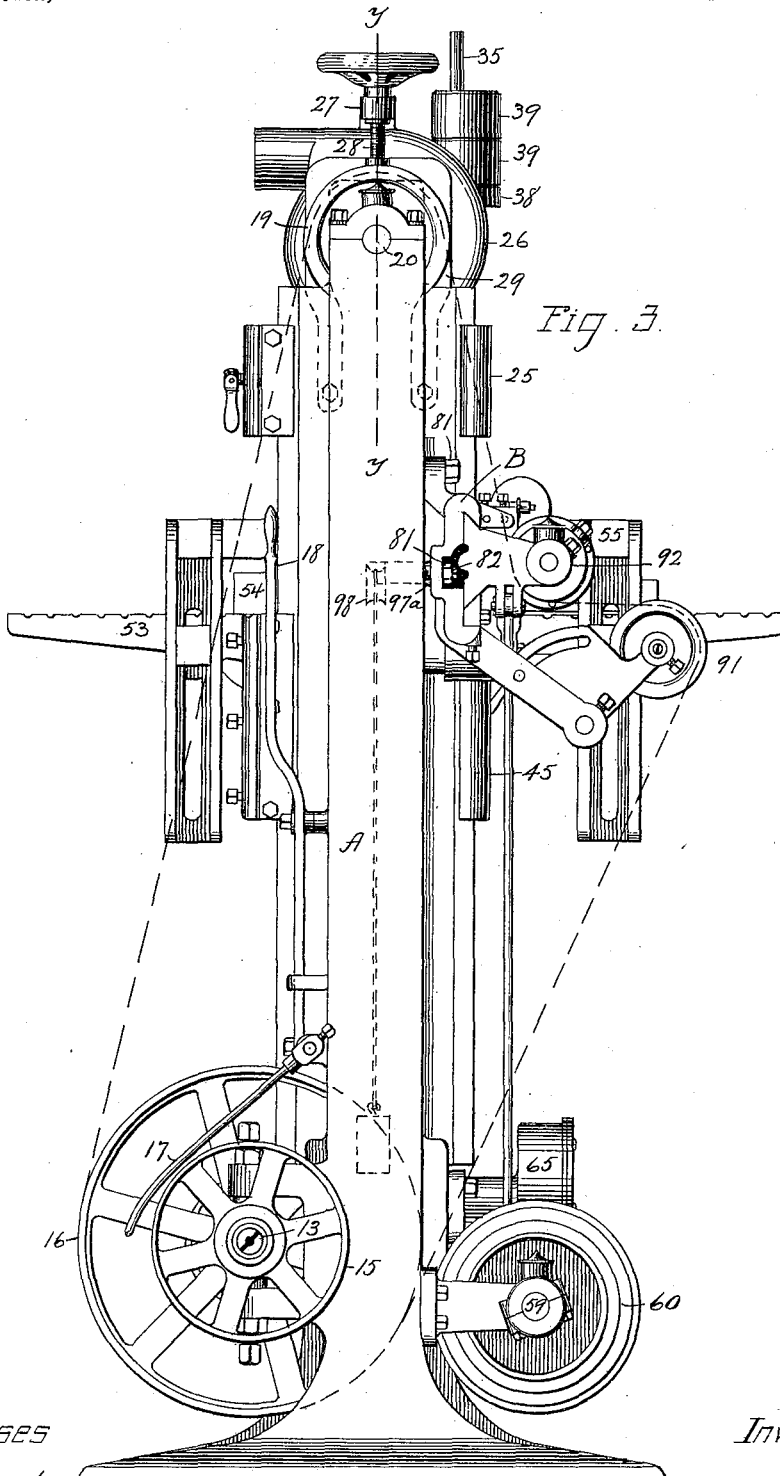

Fig. 3.

Witnesses

Geo. S. Peters
P. J. Egan

Inventor

Robert S. Brown
By James Shepard
Atty.

No. 621,026.

Patented Mar. 14, 1899.

R. S. BROWN.
CHAIN MORTISING MACHINE.

(Application filed Feb. 11, 1898.)

(No Model.)

8 Sheets—Sheet 4.

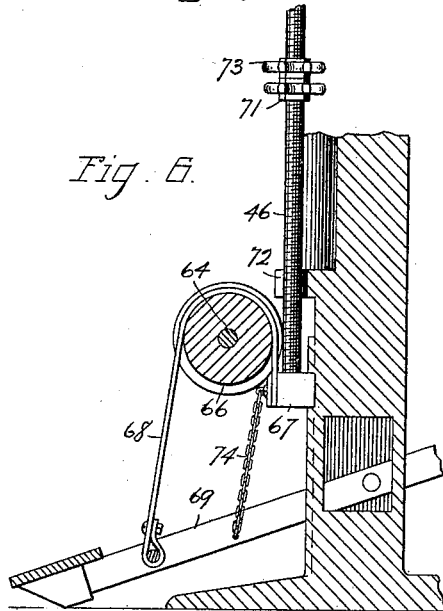
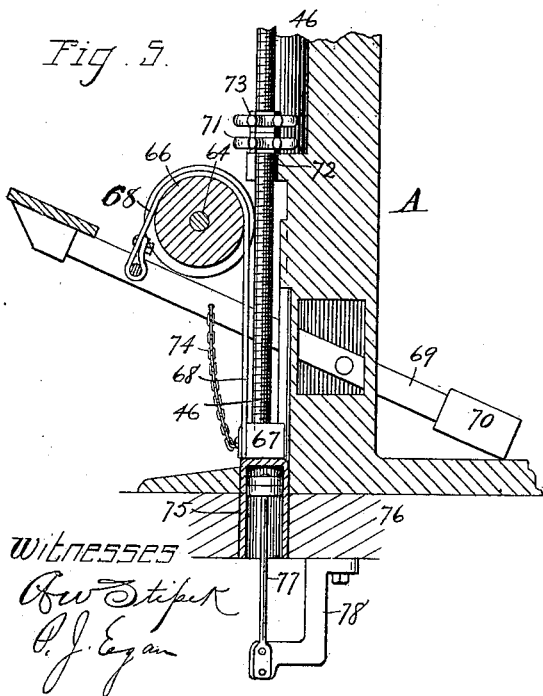
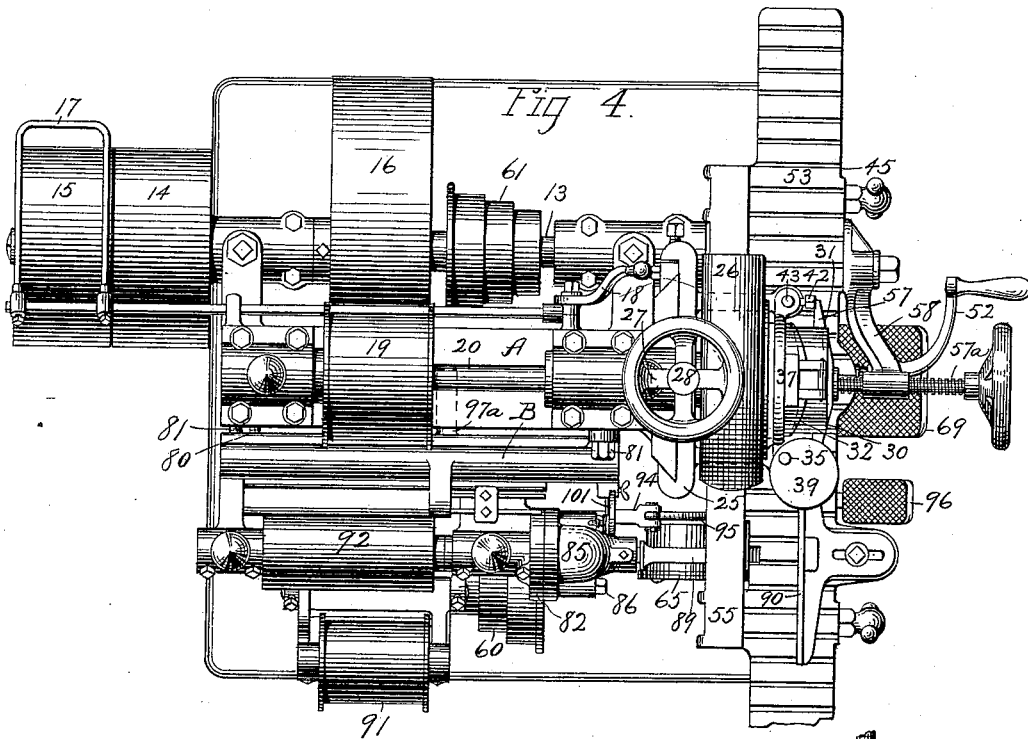

Witnesses
Geo. Steiner
A. J. Egan

Inventor
 Robert S. Brown
 By *James Shepard.*
 Atty.

R. S. BROWN.
CHAIN MORTISING MACHINE.

(Application filed Feb. 11, 1898.)

(No Model.)

6 Sheets—Sheet 5.

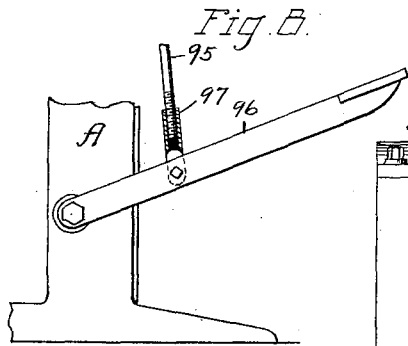

Fig. 8.

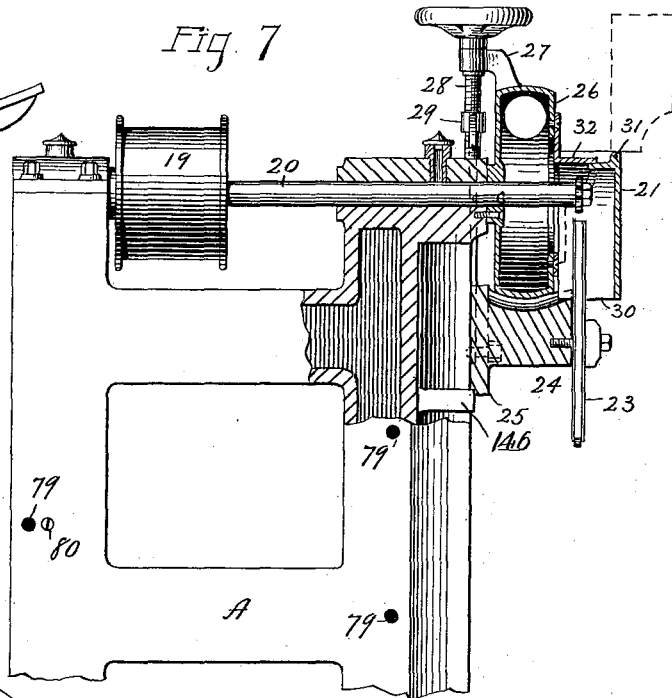

Fig. 7.

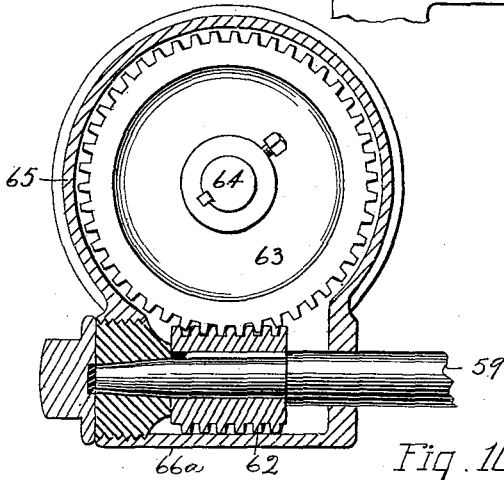

Fig. 9.

Fig. 10.

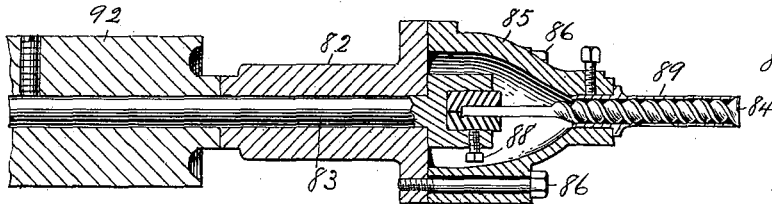
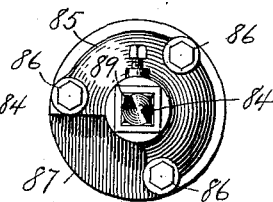

Fig. 11.



Witnesses
A. W. Shepard
C. J. Egan

Inventor
 Robert S. Brown
 By *James Shepard*
 Atty.

R. S. BROWN.
CHAIN MORTISING MACHINE.

(Application filed Feb. 11, 1898.)

(No Model.)

6 Sheets—Sheet 6.

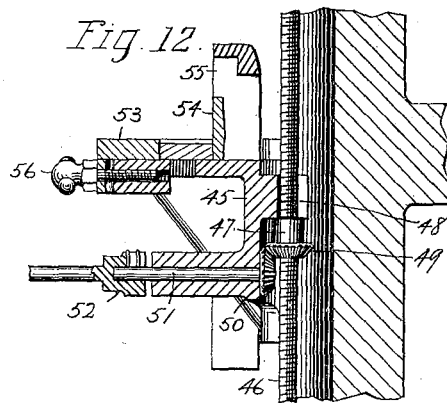
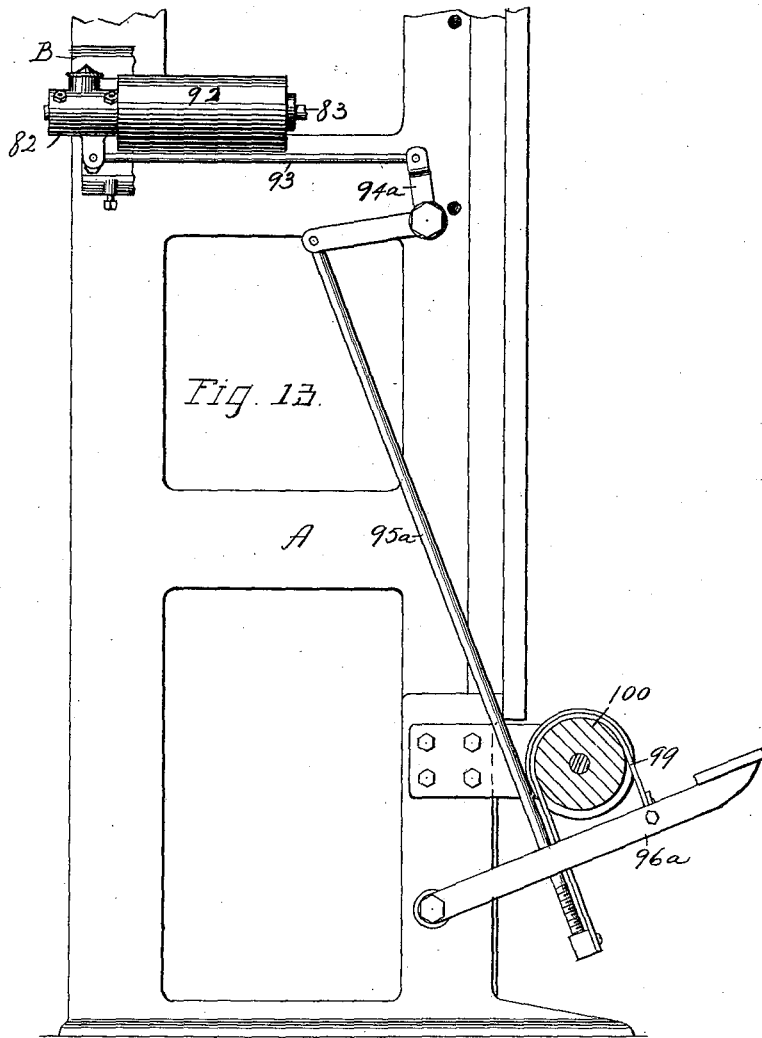

Witnesses
Abner Stipek
A. J. Egan

Inventor
 Robert S. Brown
 By *James Shepard*
 Atty.

UNITED STATES PATENT OFFICE.

ROBERT S. BROWN, OF NEW BRITAIN, CONNECTICUT, ASSIGNOR TO THE
NEW BRITAIN MACHINE COMPANY, OF SAME PLACE.

CHAIN MORTISING-MACHINE.

SPECIFICATION forming part of Letters Patent No. 621,026, dated March 14, 1899.

Application filed February 11, 1898. Serial No. 669,929. (No model.)

To all whom it may concern:

Be it known that I, ROBERT S. BROWN, a citizen of the United States, residing at New Britain, in the county of Hartford and State of Connecticut, have invented certain new and useful Improvements in Chain Mortising-Machines, of which the following is a specification.

My invention relates to improvements in chain mortising-machines; and the objects of my improvement are simplicity and economy in construction and efficiency in use.

In the accompanying drawings, Figure 1 is a front elevation of my machine. Fig. 2 is a side elevation of the same. Fig. 3 is a rear elevation. Fig. 4 is a plan view. Fig. 5 is a vertical central section of the lower portion of my machine, showing the lifting mechanism and a pneumatic stop or cushion. Fig. 6 is a like view of the same, less the cushion, with the parts in a different position. Fig. 7 is a sectional side elevation of the upper portion of my machine with the hollow-chisel mortising attachment removed, the plane of section being indicated by the line *yy* in Fig. 3. Fig. 8 is a side elevation, partly in section, of the treadle and connected parts for driving the hollow chisel. Fig. 9 is a sectional view on the line *xx* of Fig. 1, showing a part of the lifting mechanism, said figure being on an enlarged scale. Fig. 10 is a central longitudinal section, partly in elevation, of a portion of a hollow-chisel mortising attachment. Fig. 11 is an end view of the same. Fig. 12 is a central vertical section, partly in elevation, of a portion of the carriage and its slide-rod on the same scale as Figs. 1 and 7; and Fig. 13 is a sectional side elevation of a portion of the hollow-chisel mortising attachment with a modified form of its operating mechanism.

A designates the frame of the machine, in the lower part of which is mounted the main shaft 13, carrying fast and loose pulleys 14 and 15 and driving-pulley 16. The fast and loose pulleys 14 and 15 are for the main driving-belt, which is controlled in its position by any ordinary shipper 17, operated by means of the lever 18, Fig. 3. The driving-pulley 16 is designed for a belt running to the pulley 19 on the sprocket-wheel shaft 20 at the upper part of the machine. The sprocket-wheel 21 is on the outer end of the

shaft 20 and receives and drives the chain 22 of the mortising-machine. The lower part of the chain is guided by the ordinary plate or block 23, having a roller at its lower end. Said block is secured to a bracket 24 on a slide 25, that slides vertically on suitable ways, as best shown in plan view, Fig. 4. A blower-case 26 is secured (preferably by means of screws, as shown in Fig. 7) to the front part of the frame A in position to surround the shaft 20, and extending from said blower-case is a bracket 27 for supporting the adjusting-screw 28. Said screw is secured in the bracket so as to revolve freely without any longitudinal movement therein, and I prefer to have its lower end rest upon the top of the cap of the journal-box for the shaft 20. Upon the body of this screw 28 is a U-shaped yoke or strap 29, that extends down to the slide 25, to which it is secured, whereby turning the screw 28 will raise or lower the slide 25 for adjusting the tension of the chain. The shaft 20 is designed to carry an ordinary blower within the blower-case 26, and in front of said blower and covering the sprocket-wheel is a hood 30. Said hood is hinged to the front of the blower-case at 31 and arranged to shut in between flanges 32, formed on the blower-case, which hood and flanges extend along the top and two sides of the front opening in the blower-case. The blower-case opens into this hood, and the lower end of the hood is open not only for the passage of the chain, but also for receiving the chips which are made by the chain. The hood may be turned upwardly on its hinge, as indicated in broken lines, Fig. 7, in order to furnish access to the sprocket when desired.

The slide 25 is provided with bracket-arms 33 and 34, the bracket 33 being provided with a fixed bushing 34^a, which forms a bearing or guide for the sliding rod 35, to which the chip-breaker 36 is secured. At the upper end of this rod is a yoke 37, having a platform or table 38 for the weights 39, which weights can vary in number and weight as may be desired. A boss or collar 40 may be formed integral with said table and yoke and provided with a set-screw 41 for adjustably securing said table and the rod 35 together, so that raising the rod will raise the said table and parts carried thereby. The lower end of the boss 40 and upper end of the bush-

ing 34 limit the downward movement of the chip-breaker. If desired, the boss or collar may be made separately from the table without materially changing its action as to the lengthwise adjustment of the chip-breaker rod 35. I prefer, however, to make said boss or socket for said rod integral with the table, so that the rod 35 may be revolubly adjustable and may be secured against rotation by means of the set-screw 41 when adjusted. The yoke 37 extends across over the top of the sprocket-covering hood to the opposite side of the sprocket from the chip-breaker rod and has secured to it by means of the set-screw 42 on the downwardly-moving side of the endless chain a guard-rod 43, the lower end of which rod slides in the bracket 34 of the slide 25. The chip-breaker is in the main of an ordinary construction and operates in the ordinary manner; but I provide its lower end with an upwardly-curved face 44, against which the shavings from the chain are thrown when beginning to cut a mortise, and by means of said curved face the shavings are deflected upwardly, so as to be drawn into the lower end of the hood 30 by the action of the blower.

By making the blower-case detachable and supporting the adjusting-screw 28 against longitudinal movement on said case in connection with the herein-described construction I am enabled to take off said blower-case, adjusting-screw, and connected parts entire without in any way disturbing their relations to each other.

Upon the same ways that the slide 25 is mounted on I also mount the rising and falling carriage 45 at a lower part of the frame. To this carriage I connect the screw-threaded slide 46 by means of the nut 47 and slotted lug 48, which rests upon the top of said nut. The slot of said lug is open to the rear, so that the carriage may be slipped upon said screw from the front without passing the rod 46 endwise through the said lug. The nut 47 is shown only in Fig. 12 and is provided with a beveled gear 49, which engages another beveled gear 50 on the shaft 51 in the front of the carriage. The upper end of the screw-threaded rod 46 is slabbed off or flattened on two sides for a distance equal to the length of its stroke, as indicated by the broken lines at 46^a, Fig. 1, and said upper end is guided within the slotted lug 48, which opens toward the front, whereby said rod 46 is held against rotation, and in addition thereto the bottom wall of the slot in said lug prevents the upper end of said rod from moving backwardly, while the bottom wall of the slot in the lug 72 holds the lower end of said rod against moving backwardly, thereby holding the beveled gears 49 and 50 in engagement. The block 67 at the lower end of said rod 46 is also fitted to the frame A, so as to guide the lower end of said rod. The guiding and stop lug 72 and the lug 48 are also slotted, so that the slide-rod 46 may be disconnected by a sidewise instead of an endwise movement. By the ap-

plication of a suitable crank or handle 52 the nut 47 may be raised or lowered for setting the carriage at any desired height upon the screw-threaded slide. The carriage may be provided with any suitable gages and clamping mechanism. As shown, the table portion 53 of the carriage is provided with a fixed back 54 and a vertically-adjustable back 55, with its face in the same plane as the face of the fixed back. This carriage is moved from front to rear by an adjusting-screw 56 in the ordinary manner. A screw-adjustable clamp 57 is arranged to act in connection with said back and is carried by the end of the adjusting-screw 57^a in the adjustable bracket 58.

Upon one side of the frame, near its base, there is a counter-shaft 59, carrying a cone-pulley 60 for receiving a driving-belt from a companion cone-pulley 61 on the main shaft. This counter-shaft 59 carries near its forward end a worm 62, which engages with and drives the worm-gear 63 on the shaft 64, Fig. 9. This worm-gear is covered by a case 65, while the worm is covered by a case 66^a. The shaft 50, upon which the worm is mounted, is provided with a pulley 66, located in front of the lower end of the screw slide-rod 46. The lower end of the slide-rod 46 is provided with a block or cross-bar 67, to which the lower end of a belt 68 is secured, while the other end of said belt is secured to the bifurcated treadle 69, the body of the belt passing over the pulley 66. This treadle 69 is partially counterbalanced by means of the weight 70, so that the treadle of itself will not draw the belt tightly enough against the periphery of the pulley 66 to create sufficient friction thereon to lift the operating-rod and its carriage. The weight 70, however, is not heavy enough to overbalance the foot-pad end of the treadle, whereby the excess in weight of said foot-pad end will always act by gravity to keep the belt in contact with the pulley 66, as shown, with a tendency to check the descent of the carriage after the operator's foot is removed from the treadle. At the same time said foot-pad end must not be heavy enough to make the belt lift the carriage. In all cases the upward movement of the foot-pad end of the treadle—that is, the return movement of said treadle in the direction opposite that in which it is moved for driving the said operating-rod—is limited by means of the adjusting-nut 71 on the slide-rod 46 and not by any obstruction or stop that the treadle acts upon. If the return movement of the treadle for dropping the carriage was limited by the treadle itself instead of by the stop-nut 71 on the rod 46, then the whole weight of the carriage would be thrown on the belt as soon as the treadle was so stopped and cause sufficient friction on the belt and pulley to lift the carriage again, and so on repeatedly. The treadle 69 and pulley 66 are on different axes, and the treadle end of the belt 68 is connected with the treadle on so great a radius that the arc of contact between said belt and pulley is

practically the same throughout the movement of the treadle, as shown by a comparison of the upper and lowermost positions of the treadle in Figs. 5 and 6, whereby the lifting power of the pulley is substantially uniform during the entire lifting movement of the carriage. The downward movement of the slide-rod and carriage is limited by means of the adjusting-nut 71 on the threaded portion of said slide-rod and the lug 72 on the frame, against which lug said nut abuts in the lowermost position of said slide-rod. This lug 72 is slotted and opens to the front. The nut 71 may be additionally secured by means of the set-nut 73. I also connect the lower end of the slide-rod and the treadle by means of a flexible connection in the form of a chain 74 or an equivalent for said chain.

The driving-pulley 66 when the machine is in use revolves continuously. When it is desired to raise the carriage, the treadle 69 is depressed, which act of itself would tend to raise the carriage even if the pulley 66 merely rolled; but by having the pulley driven by power depressing the treadle brings the driving-belt 68 against the periphery of the pulley and creates sufficient friction to make the pulley drive the belt, and thus lift the slide-rod and carriage. If the treadle is not depressed with sufficient force, the pulley may slip a little, so that the slide-rod will not be raised as fast as the pulley travels; but no matter how hard the treadle may be depressed the carriage can never be raised at a greater speed than the periphery of the pulley travels. As soon as the pressure of the treadle is released the carriage and slide-rod descend to their normal position. In order to prevent the carriage from ever being forced too far upwardly, I attach the chain 74 or equivalent flexible connection, which is so arranged as to be slack when the carriage is at its lowermost position, as shown in Fig. 5, and short enough to be drawn taut as the slide-rod reaches its uppermost position, as shown in Fig. 6, so that the slide-rod through said chain pulls the treadle upwardly and releases the pressure of the belt 68 on the pulley 66, so as to stop the upward movement of the carriage even if the operator should continue the pressure upon the treadle for too long a time.

In Fig. 5 there is illustrated a pneumatic cushion for checking the downward movement of the carriage, which is especially useful in large machines. This consists of a cylinder 75, attached to the under side of the block 67 of the slide-rod and extending down through the frame and the floor 76. A piston 77 is fixed upon a bracket 78, secured to the under side of the floor, whereby said piston and cylinder form a pneumatic check to cushion the downward movement of the carriage. Of course this pneumatic cushion may be differently located and may be omitted when desired.

The machine thus far described is for the

ordinary use of a chain mortising-machine, but in some instances a mortise is desired of less dimensions than can be formed by means of a chain. Such mortises are formed with a boring-bit and hollow chisel. In the frame A at one side I drill and tap three holes 79, as shown in Fig. 7, for the attachment of a hollow-chisel mortising mechanism. I also provide the said frame with an adjustable leveling-screw 80. B designates the frame of the hollow-chisel mortising mechanism, which frame I secure to the main frame by means of bolts 81, Figs. 2 and 3, which extend into the holes 79. The leveling-screw 80 (shown in Figs. 4 and 7) may be turned out and in, so as to square this hollow mortising-machine with the table, bringing the bit and chisel of said machine into a position at right angles to said table. A lathe-head 82, carrying a driving-spindle 83 for the boring-bit 84, Fig. 10, and long pulley 92, is mounted to slide longitudinally on suitable ways in the frame B, as best shown in Fig. 3. The front end of this lathe-head has a tapering hood-like chuck 85, secured to it by means of bolts 86, said hood being left open upon one side, as at 87, Fig. 11, to furnish access to the set-screw 88, that holds the boring-bit in its holder. The said chuck 85 has also fixed in it a hollow chisel 89. It is essential that the hollow chisel shall always be concentric with the boring-bit and that the boring-bit shall be in alignment with its spindle. This can always be accomplished by adjusting the position of the chuck 85 on the end of the lathe-head, the bolt-holes in which chuck are large enough to permit of such adjustment. The table of the carriage 53 may be provided with any suitable abutment or backing 90, with its face arranged at a right angle to the top of said carriage to support the work in position for being acted upon by the hollow chisel 89 and boring-bit 84. The frame B of the hollow-chisel mortising-machine is also provided with an adjustable idle-pulley 91, and the belt, which drives the sprocket-shaft 20, may extend from the pulley 16 over the idle-pulley 91, under the long pulley 92, and up over the pulley 19 on the shaft 20, as indicated by broken lines in Fig. 3. By thus arranging the belts the one belt, which drives the sprocket-shaft 20, may also drive the spindle for the boring-bit. At the same time in case the hollow-chisel mortising attachment is not present the belt may run directly from the pulley 16 to the pulley 19 in the ordinary manner. The sliding lathe-head 82 has secured to it a link 93, one end of which link is secured to the short arm of the angle-lever 94. A rod 95 depends from the long arm of said angle-lever 94 down to the treadle 96. I prefer to connect said rod with the treadle by means of a socket-block 97, screw-threaded on its interior and into which the threaded lower end of the rod 95 is screwed. As seen in Figs. 1 and 4, the treadles 69 and 96 are arranged side by side, and it is desirable that when in their normal position they

should stand at the same height. This may be accomplished by the threaded connection at the lower end of said rod 95, as illustrated in Fig. 8. By depressing this treadle 96 the lathe-head 82, with its boring-bit and hollow chisel, are forced forward toward their work, which lies against the abutment 90 on the table. For use in connection with this attachment the carriage should be set higher than the position shown in Fig. 2. The bit and chisel may pass through the opening in the adjustable back 55 of the chain mortising-machine carriage. The lathe-head 82 is drawn backwardly into the position in Fig. 2 by means of a weight and cord attached to an arm 97 of the head 82, which cord extends over a pulley 98, while the weight passes down one of the hollow columns of the frame A, as indicated in broken lines, Fig. 3.

Upon the frame B of the hollow-chisel mortising-machine I place a mirror 101, which faces to the front and shows the work directly in front of the hollow chisel and bit, so that the operator by looking in the mirror can see just what the machine is doing and how the work is done.

If desired, instead of the treadle 96 for forcing the boring-bit and hollow chisel to its work I may move said head forwardly by power in the manner similar to that of raising the carriage of the chain mortising-machine. In Fig. 13 I have illustrated such a power mechanism in connection with portions of the head 82 and adjacent parts. I employ the same link or connecting-rod with an angle-lever 94^a, to the long arm of which is a rod 95^a, connected with a belt 99, pulley 100, and treadle 96^a. This pulley 100 is arranged to be driven slowly the same as the pulley 66, and the general operation is the same as that of the mechanism for lifting the main carriage, excepting as operating the rod 95^a operates the angle-lever 94^a to move the head 82 horizontally instead of vertically. Such operating-rod 95^a and the slide-rod 46 first described are equivalent operating-rods for the purposes of a mortising-machine-operating mechanism.

The machine may be sold either with or without the hollow-chisel mortising attachment. By my improvements the main frame of the machine, its main shaft, &c., can be used for both kinds of mortising, making the expense much less than two separate machines, while the compound machine occupies practically no more shop-room than an ordinary chain mortising-machine.

For mortising with the chain 22 after adjusting the carriage and connected parts for the desired work the wood to be mortised is clamped on the table, the chip-breaker and its rod adjusted and weighted as desired, and then the carriage, with the work on it, is forced upwardly to the chain by means of the treadle 96 and cooperating parts. The chip-breaker, with its rod, weighted yoke, and guard-rod, rise up with the work as it is fed up to the chain. The chips are taken by the blower and car-

ried to any desired place. By making the upwardly-curved face on the chip-breaker the first chips or shavings cut by the chain are carried directly into the draft of the blower instead of being scattered in the room, as heretofore. By means of the hood hinged at the top, extending down on each side of the blower opening and shutting into flanges, as described, I extend the draft of the blower much nearer to the work than formerly, whereby the chips are more effectually removed. By releasing the pressure on the treadle the carriage is lowered to its normal position. In lifting the carriage the operator may, if desired, throw his whole weight upon the foot-treadle.

It is apparent that some changes from the specific construction herein disclosed may be made, and therefore I do not wish to be understood as limiting myself to the precise form of construction shown and described, but desire the liberty to make such changes in working my invention as may fairly come within the spirit and scope of the same.

I claim as my invention—

1. The combination of the sprocket-wheel shaft 20, with the blower-case fixed on the frame of the machine, the adjusting-screw 28 supported from said blower-case, and held against longitudinal movement thereon, the yoke 29 longitudinally movable on said screw and the slide 25 connected with said yoke, whereby said case, screw, yoke and slide may all be removed intact, substantially as described.

2. The blower-case surrounding the sprocket-wheel shaft open at its front, provided with flanges around the said front opening on the top and two sides thereof and having the hood 30 hinged thereon by its upper end and arranged to shut into said flanges, substantially as described.

3. The slide 25 carrying the chain-block and having brackets 33 and 34, in combination with the chip-breaker rod sliding in the bracket 33 on one side of said chain-block, the guard-rod 43 sliding in the bracket 34 on the opposite side of said chain-block and the weighted yoke 37 connecting the said two rods at their upper portions, substantially as described.

4. The chain-block and chain, in combination with the chip-breaker rod arranged to slide vertically by the side of said chain, a chip-breaker at the lower end of said rod, a table 38 on the said rod, a weight on said rod above the said chip-breaker above said table and devices for adjustably connecting said rod and table, substantially as described.

5. The combination of the sprocket-wheel shaft and blower with the chain driven by said shaft, the sliding chip-breaker rod, and the chip-breaker secured to said rod and provided with the upwardly-inclined curved face 44 for deflecting the first chips up to the draft of the blower, substantially as described.

6. The combination of the frame having

vertical ways for a carriage and slotted lugs opening toward the front, a mortising-chain and its operating mechanism, the carriage mounted on the said vertical ways of the frame and having the slotting-lug open toward the rear, the vertically-moving screw-threaded slide-rod received in the slotted lugs of said frame and carriage, the nut 47 on said rod upon which nut the said carriage rests, and mechanism for lifting the said slide-rod, substantially as described.

7. The combination of the vertically-moving carriage having a slotted lug opening toward the rear, with the vertically-moving and screw-threaded slide-rod, means for confining the upper and lower portions of said slide-rod, means for lifting said slide-rod, the nut 47 on said rod with the slotted lug of said carriage resting thereon, the beveled wheel on said nut, a companion beveled wheel on operating-shaft, and a crank or handle for turning the said beveled wheels and nut, substantially as described.

8. In a mortising-machine the combination of an operating-rod, with a driving-pulley and its axis, a driving-belt on said pulley, connected by one end to said operating-rod and a treadle mounted on a separate axis from that of said driving-pulley and connected with the other end of said driving-belt, whereby the arc of contact between said belt and pulley is substantially the same throughout the stroke of said operating-rod, substantially as described.

9. In a mortising-machine, the combination of an operating-rod, with a driving-pulley, a driving-belt on said pulley connected by one end to said operating-rod, and a partially-counterbalanced treadle with the excess of weight on its foot-pad end, said treadle being connected with the opposite end of said belt and acting by gravity to hold the said belt in contact with the said pulley, substantially as described.

10. An operating mechanism for mortising and analogous machines consisting of the combination of an operating-rod, a driving-pulley, a driving-belt on said pulley connected by one end to said rod, a treadle connected with the other end of said belt and a chain connecting said operating-rod and treadle whereby the power is automatically removed from the operating-rod when it reaches a certain position, substantially as described.

11. The combination of the screw-slide or operating rod, the carriage mounted on said rod and vertically adjustable thereon, a slotted stop-shoulder lug 72 for receiving a threaded portion of said rod below its carriage-nut-holding portion at the lower part of the frame, and a stop-nut 71 on said screw-slide rod for acting on said stop-shoulder lug, substantially as described.

12. The combination with the frame of a chain mortising-machine, the main shaft and pulley 16, the sprocket-wheel shaft and pulley 19, a hollow-chisel mortising attachment

having a sliding head and a long pulley 92 within the range of the said pulleys 16 and 19 and adapted to be driven by the same belt, substantially as described.

13. The chain mortising-machine, its operating-treadle, the hollow-chisel mortising attachment, in combination with an operating-rod for said attachment, a treadle for said operating-rod, and a screw-adjustable connection of said treadle and rod for bringing the foot-pads of the said two treadles to practically the same height, substantially as described.

14. The combination of the frame of a chain mortising-machine, the carriage mounted thereon, an abutment on said carriage having a face that stands at a right angle to the top of said carriage, the hollow-chisel mortising attachment secured to one of the vertical sides of the said frame in position for use in connection with said carriage, and a leveling-screw 80 for adjusting the bit and chisel of said hollow-chisel mortising attachment in relation to said carriage, substantially as described.

15. The combination of the sliding lathe-head 82 of the hollow-chisel mortising-machine, with the spindle for the boring-bit mounted in said head, the hood-shaped chuck having at its smaller end the holding-socket for the chisel and having its larger end extended to the rear of the said socket for the chisel and means for adjustably fixing the said chisel-chuck upon said head, substantially as described.

16. The combination of the sliding lathe-head 82 having a chuck-seat at its outer end, with the spindle for the boring-bit projecting in front of said chuck-seat, a bit-holder on the projecting end of said spindle, and the hood-shaped chisel-chuck of a conoidal hollow form, but open on one side, having a base that surrounds the said bit-holder and is secured to the chuck-seat in the rear thereof, and having also the chisel-socket at its smaller end, substantially as described.

17. The combination of the endless chain of a chain mortising-machine, with the vertically-sliding guard-rod arranged on the downwardly-moving side of said chain, substantially as described.

18. The combination of a frame, with an operating-rod, a driving-pulley, a driving-belt on said pulley connected by one end to said operating-rod, a partially-counterbalanced treadle connected with the opposite end of said belt, and a stop on the said operating-rod acting in connection with the frame to limit the movement of the said treadle in the direction opposite that which the said treadle is moved for driving the said operating-rod, substantially as described.

ROBERT S. BROWN.

Witnesses:

H. E. ERWIN,

GEO. E. ELLIOTT.